



Flanged housings FNL series

Bearing types

- Self-aligning ball bearings
- Spherical roller bearings
- CARB toroidal roller bearings

Bearing dimension series

- 02, 22

Shaft diameter range

- 20 to 100 mm

Typical shaft-bearing combinations

- Plain shaft with bearing on an adapter sleeve

Seals

- Double-lip

Lubrication

- Grease

Materials

- Grey cast iron

Mounting

- Three-bolt mounting
- Four-bolt mounting

Compliance to standards

- Not standardized

Supersedes

- 7225(00)

FNL flanged housings are well-proven machine parts that provide simple, reliable housing in applications without horizontal frames. They enable the full service life potential of the incorporated bearings to be exploited with less need for maintenance.

11

Flanged housings FNL series

Designations	533	Product tables	
Standard housing design	535	11.1 FNL flanged housings for	
Features and benefits	536	bearings on adapter sleeves.....	546
Housing material	536		
Paint, corrosion protection	536		
Dimension standards	537		
Interchangeability	537		
Housing variants	537		
Centring recesses	537		
Grease escape hole	537		
Sealing solutions	538		
Design considerations	539		
Typical shaft-bearing combinations ...	539		
Locating and non-locating			
bearing positions	539		
Load carrying ability	540		
Operating temperature	540		
Operating speed	541		
Attachment bolt recommendations....	541		
Lubrication	542		
Initial grease fill	542		
Relubrication	542		
Mounting	544		
Condition monitoring	544		
Accessories	544		
Ordering information	545		

Designations

Designation system for FNL flanged housings

FNL 505 A

Series

FNL Flanged housing

Size identification

5(00) Housing for bearings on an adapter sleeve, diameter series 2
(00) Size code of the bearing, (00) × 5 = bore diameter [mm]

Suffixes¹⁾

A Housing for shaft end with end cover
B Housing for through shaft
P Housing with machined recess for guide ring
V Housing with grease escape hole in the housing cover

¹⁾ When multiple suffixes are used, they are listed in the same order as shown here.

Designation system for seals

TFL 505

Series

TFL Double-lip seal for FNL flanged housings

Size identification

... Size code of the housing

Flanged housings FNL series

Designation system for locating rings

FRB 5/52

Series

FRB Locating ring for SKF bearing housings

Size identification

... Width and outside diameter of the locating ring [mm]

Designation system for spacing washers

ZW 42 × 52

Series

ZW Spacing washers for SKF bearing housings

Size identification

... Bore and outside diameter of the spacing washer [mm]

Standard housing design

FNL flanged housings are non-split housings that are produced in two designs depending on size. Smaller sizes up to and including size 13 have a triangular flange (→ **fig. 1**), larger sizes have a square flange (→ **fig. 2**). FNL housings are supplied with a cover either for shaft ends or for through shafts (→ **fig. 3**). The housings with a cover for shaft ends have the designation suffix A, the housings with a cover for through shafts have the designation suffix B.

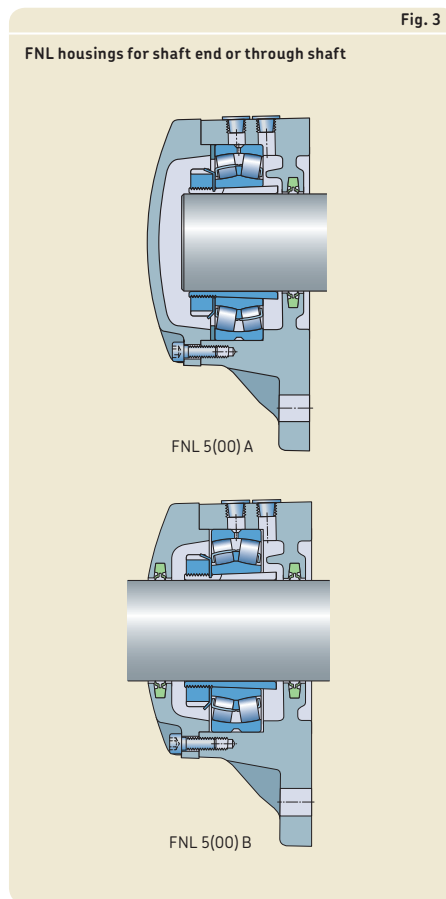
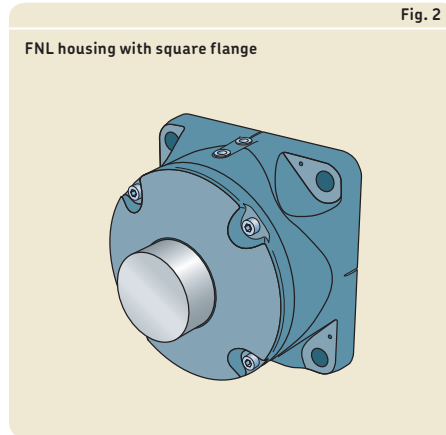
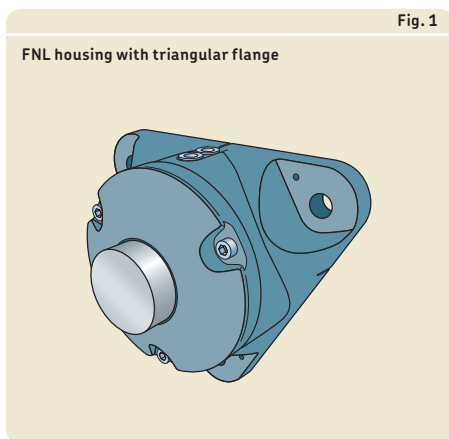

Flanged housings FNL series

Features and benefits

FNL flanged housings have the following features and benefits:

Simple mounting

To simplify mounting and make alignment more accurate, lines cast into the housing flange indicate the centre of the housing bore. Dimples indicate the position for dowel pins (→ fig. 4).

Grease guiding system

An integrated flange guides grease from the grease fitting into the bearing (→ fig. 5).

Low friction seals

A low friction, double-lip seal on each side of the housing keeps grease in and contaminants out (→ fig. 6). These seals allow rotational speeds twice that of traditional felt seals.

Drilled holes for relubrication

FNL housings have two predrilled holes for relubrication. One is centered and enables relubrication via a lubrication feature in the bearing. The other is offset and enables relubrication from the side.

Housing material

FNL flanged housings are made of grey cast iron.

Paint, corrosion protection

FNL flanged housings are painted black (RAL 9005) using a water based alkyd/acryl paint. The paint protects the housing in accordance with ISO 12944-2, corrosivity category C2 (i.e. exterior atmospheres with low level of pollution, interior atmospheres where condensation may occur). The paint is not affected by most lubricating or engine oils, cutting fluids or alkalescent washing chemicals. Housings can be repainted with most water or solvent based 1- or 2-component paints.

Unpainted surfaces are protected by a solventless rust inhibitor.

Fig. 4

Cast indications mark the centre of the housing bore

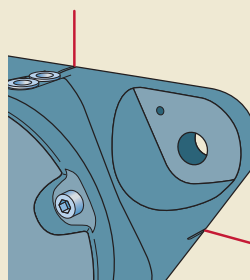

Fig. 5

Grease guiding system

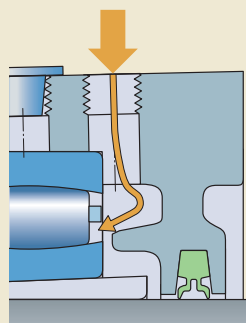
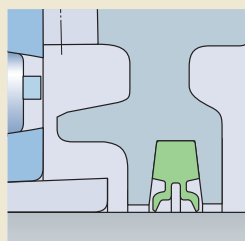

Fig. 6

Low friction seals



Dimension standards

The dimensions of FNL flanged housings are not standardized either nationally or internationally.

Interchangeability

FNL flanged housings are dimensionally interchangeable with the earlier 7225(00) housings.

Housing variants

In addition to standard design FNL flanged housings, variants are also available. Variants include housings with centring recesses and grease escape holes.

Centring recesses

FNL flanged housings can be supplied with a machined recess, which can be used to centre the housing on a shoulder. With this arrangement, the attachment bolts are not subjected to shear forces. The shoulder can be provided either by machining the wall or by attaching a guide ring to the wall.

FNL housings with a machined recess can be supplied on request and are identified by the designation suffix P, e.g. FNL 511 BP. Dimensions for the recess and the shoulder or guide ring are listed in **table 1**.

Grease escape hole

FNL flanged housings can be supplied with a grease escape hole in the cover (→ **fig. 7**). This housing variant can be supplied on request and is identified by the designation suffix V, e.g. FNL 511 AV.

Table 1

Centring recess on FNL housings

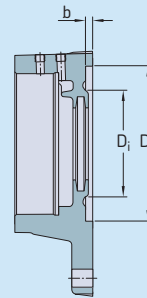

Housing Size	Recess dimensions		
	b	D _y H8	D _i
–	mm		
FNL 505	3	60	35
FNL 506	3	70	48
FNL 507	4	80	53
FNL 508	4	90	60
FNL 509	4	100	65
FNL 510	5	100	68
FNL 511	5	105	78
FNL 512	5	120	90
FNL 513	5	130	90
FNL 515	6	150	105
FNL 516	6	150	110
FNL 517	6	170	120
FNL 518	7	170	120
FNL 520	6	200	140
FNL 522	6	220	160

Fig. 7

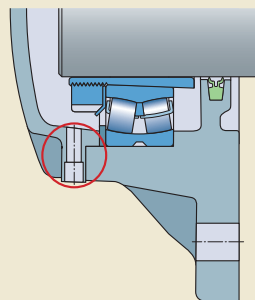

Flanged housings FNL series

Table 2

Double-lip seals for FNL flanged housings

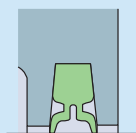

Type	Double-lip
Designation	TFL 5..
Size range	505 to 522
Material	HNBR (hydrogenated nitrile butadiene rubber)

Application conditions and requirements

Temperature [°C]	-25 to +120
Temperature [°F]	-15 to +250
Max. circumferential speed ¹⁾ [m/s]	8
Max. misalignment [°]	0,5
Low friction	+
Axial shaft displacement	++
Vertical shaft arrangement	+
Replacement	+
Shaft tolerance class	h9(Ⓜ)
Shaft roughness R_a [μm]	≤ 3,2

Sealing suitability

Dust	++
Fine particles	++
Coarse particles	++
Chips	+
Liquids when sprayed	+
Direct sunlight	+

Symbols: ++ very suitable
+ suitable

¹⁾ To convert circumferential speeds to rotational speeds
→ table 7 on page 37

Sealing solutions

FNL flanged housings are equipped with low-friction, double-lip grease seals (→ fig. 8).

Table 2 provides an overview of the characteristics and suitability of the sealing solution. This information should be used as a guideline and does not substitute for testing a seal in its application.

Seals are supplied with the housing. If additional seals are needed, they can be ordered separately. They are identified by the designation prefix TFL followed by a number indicating the size, e.g. TFL 511.

Fig. 8



Design considerations

For general information about system design, refer to the following sections:

- *Typical shaft-bearing combinations* (→ **page 41**)
- *Locating/non-locating bearing systems* (→ **page 40**)
- *Load carrying ability* (→ **page 44**)
- *Axial load carrying ability for bearings on a sleeve* (→ **page 44**)
- *Specifications for shafts and housing support surfaces* (→ **page 45**)

For additional information about rolling bearings and adapter sleeves, refer to the product information available online at skf.com/bearings.

Typical shaft-bearing combinations

FNL flanged housings can accommodate bearings on an adapter sleeve on plain shafts.

Locating and non-locating bearing positions

FNL housings can be used for both the locating and non-locating bearing positions. The housings are machined standard for bearings in the non-locating position. Bearings in the locating position as well as CARB toroidal roller bearings must be secured in the housing with a spacing washer or one or two locating rings (→ **fig. 9**). Appropriate spacing washers and locating rings are listed in the product tables.

When a spacing washer or only one locating ring is used, it should be inserted on the cover side of the bearing. When two locating rings are used, one should be placed on each side of the bearing.

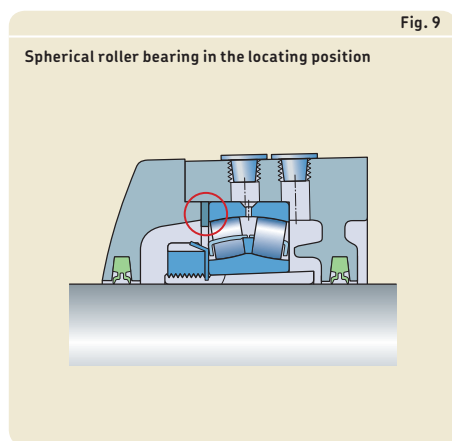

Flanged housings FNL series

Load carrying ability

The permissible radial loads for a flanged housing depend on the bearing, the breaking load of the housing and the strength of the attachment bolts. Guideline values for the breaking loads of the housings are provided in **table 3**.

The permissible axial loads for a flanged housing are limited by the friction between the sleeve and shaft.

Additional housing support

When the housing is subjected to heavy radial loads, a stop or dowel pins should be used to relieve the load on the attachment bolts. A shoulder or a guide ring on the support surface engaging a centring recess can also be used. Whichever method is used, it should be sufficiently strong to accommodate the loads acting parallel to the support surface.

Recommendations for the position and size of the holes to accommodate dowel pins are provided in **table 4**. Dimples cast into the housing flange mark the recommended positions.

Operating temperature

The permissible operating temperature is mainly limited by the seals (→ **table 2, page 538**) and the lubricant. For temperature limits of SKF bearings and lubricants, refer to the product information available online at skf.com/bearings.

The housing material does not set any additional temperature limits, except for very low temperature applications where impact strength could be a factor.

The housing paint is heat resistant up to 80 °C (175 °F) material temperature or 100 °C (210 °F) ambient temperature.

When temperatures outside the permissible range are expected, contact the SKF application engineering service.

Table 3

Breaking loads for FNL housings

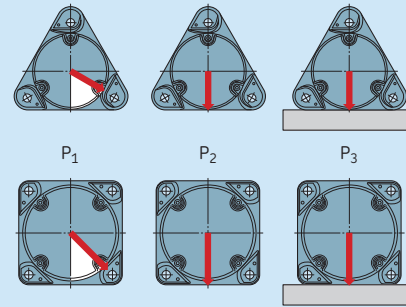

Housing Size	Breaking loads		
	P ₁	P ₂	P ₃
–	kN		
FNL 505	50	40	80
FNL 506	60	45	85
FNL 507	70	50	90
FNL 508	80	55	95
FNL 509	90	60	100
FNL 510	100	65	105
FNL 511	110	80	110
FNL 512	120	95	115
FNL 513	130	110	190
FNL 515	140	125	265
FNL 516	150	140	340
FNL 517	160	155	415
FNL 518	170	170	490
FNL 520	180	185	565
FNL 522	190	200	640

Table 4

Position and size of dowel pin holes

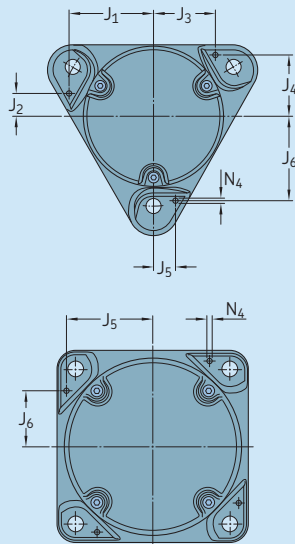

Housing Size	Dimensions						
	J ₁	J ₂	J ₃	J ₄	J ₅	J ₆	N _{4 max}
–	mm						
FNL 505	44	12	33	32	12	44	5
FNL 506	51	13	37	37	13	51	5
FNL 507	57	16	42	41	15	57	5
FNL 508	65	17	48	47	16	66	6
FNL 509	71	20	53	52	18	72	6
FNL 510	71	20	53	52	18	72	6
FNL 511	77	21	57	56	21	77	6
FNL 512	84	22	62	61	22	84	8
FNL 513	90	24	66	66	24	90	8
FNL 515	–	–	–	–	85	55	8
FNL 516	–	–	–	–	87	54	8
FNL 517	–	–	–	–	93	63	8
FNL 518	–	–	–	–	95	60	8
FNL 520	–	–	–	–	112	72	8
FNL 522	–	–	–	–	122	78	8

Operating speed

The seals can limit the permissible operating speed. They are suitable for circumferential speeds of up to 8 m/s. The corresponding rotational speeds are listed in **table 7** on **page 37**. For speed limits of the bearing, refer to the product information available online at skf.com/bearings.

Attachment bolt recommendations

In typical applications, 8.8 class hexagon head bolts in accordance with ISO 4014 can be used together with washers in accordance with ISO 7089 or 7090. SKF housings can withstand loads resulting from tightening the attachment bolts to the torque values recommended by bolt manufacturers (→ **table 6, page 544**). They are valid for oiled, but otherwise untreated, thread surfaces.

If the bearing arrangement is subjected to heavy radial loads, it may be necessary to use stronger, 10.9 class bolts.

SKF cannot guarantee that tightening to the recommended value will provide sufficient anchoring. Make sure that attachment bolts, dowels or stops, shoulder or guide ring can accommodate all occurring loads.

Flanged housings FNL series

Lubrication

FNL flanged housings are designed for grease lubrication. The lubricant should be selected based on the operating conditions of the bearing. For additional information about lubricant selection, refer to the product information available online at skf.com.

Initial grease fill

If no other requirements exist, the free space in the bearing should be completely filled with grease and the free space in the housing should be filled to 20 to 40% of its volume. A 40% grease fill is required when bearings have to be relubricated from the side, while a 20% grease fill is used when bearings are relubricated via the outer ring.

For highly contaminated environments and slow speeds, fill the housing to 70–80%. For additional information, contact the SKF application engineering service.

Quantities for 20 and 40% grease fills are listed in **table 5**.

The values are valid for a typical lithium grease (about 0,95 g/cm³). They include grease for the bearing and the seals.

In most applications, the initial grease fill will adequately lubricate the bearing until the grease is exchanged during the next planned inspection.

Relubrication

Certain operating conditions such as high speeds, high temperatures or heavy loads may require relubrication. Therefore FNL housings have two holes that have been drilled and tapped for an AH 1/8-27 PTF grease fitting (→ **fig. 10**). On a new housing, the holes are covered by plastic plugs. These plugs should be replaced with the grease fitting and the threaded plug supplied with the housing. If a larger grease fitting or other equipment has to be used an adapter to change to a G 1/4 thread is available (→ **page 48**).

Excess grease can escape via the seals. If this is not enough, SKF can supply housings with a grease escape hole in the cover (designation suffix V) on request. SKF recommends removing the housing cover periodically to remove used grease. The time interval for this

Table 5

Housing Size	Initial grease fill	
	20%	40%
–	g	
FNL 505	10	15
FNL 506	15	25
FNL 507	25	35
FNL 508	30	45
FNL 509	35	50
FNL 510	35	50
FNL 511	40	60
FNL 512	60	90
FNL 513	80	120
FNL 515	150	250
FNL 516	180	300
FNL 517	210	350
FNL 518	250	400
FNL 520	320	500
FNL 522	420	650

Fig. 10

Relubrication holes

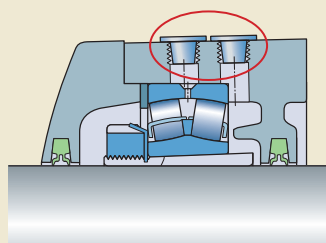

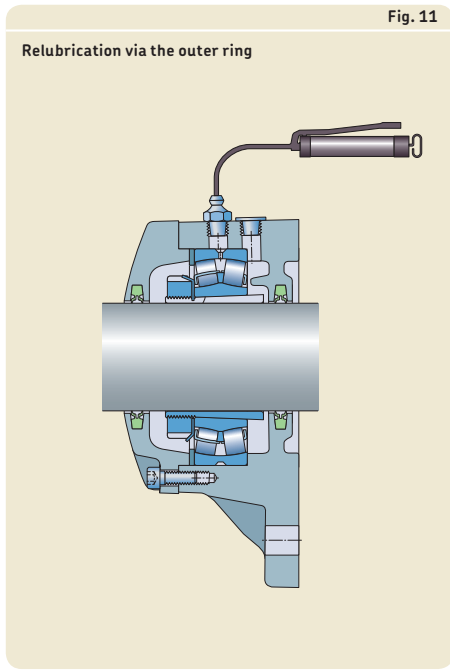

depends on the application, the size of the bearing and the amount of grease applied.

Relubrication via the outer ring

The hole closest to the cover should be used to relubricate spherical roller bearings with a relubrication feature (a lubrication groove and holes in the outer ring) (→ fig. 11). When applying grease via the relubrication feature the shaft should be rotating.

Relubrication from the side

When relubricating from the side, which is typically necessary for self-aligning ball bearings and CARB toroidal roller bearings, the hole closest to the flange should be used (→ fig. 12).

FNL flanged housings have an integral flange that guides grease from the grease fitting directly to the rolling elements (→ fig. 13).

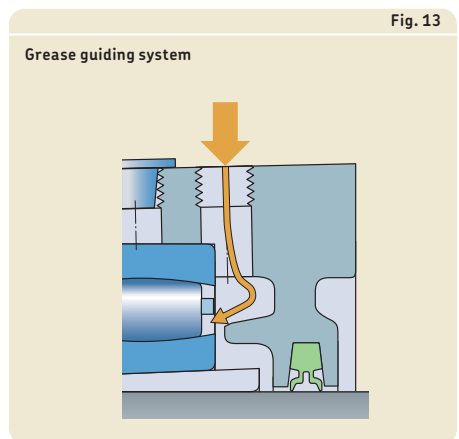
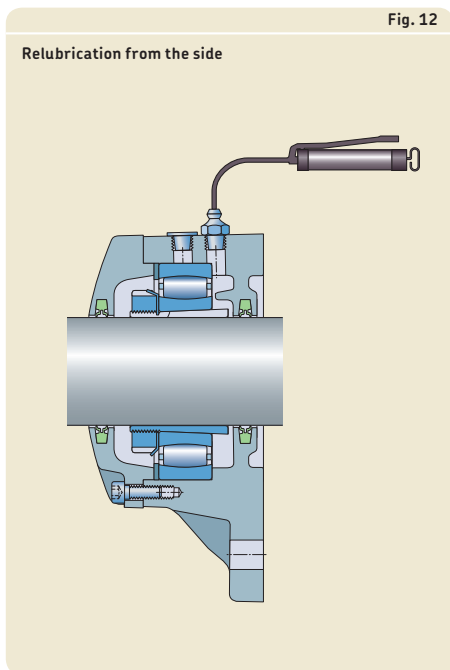

Flanged housings FNL series

Mounting

FNL housings must be mounted properly using the appropriate tools and state of the art mechanical mounting methods. All the associated components must also meet certain basic requirements (→ *Specifications for shafts and housing support surfaces* on **page 45**).

Mounting instructions are provided with the housing. For information about mounting rolling bearings, refer to the *SKF bearing maintenance handbook* or skf.com/mount.

Torque specifications

Cover bolts and attachment bolts should be tightened to the torque values listed in **table 6**.

Condition monitoring

If connections for condition monitoring sensors are required, contact SKF.

Accessories

There are several accessories available for FNL housings, including lubricators, central lubrication systems and adapters for grease fittings. For additional information, refer to *SKF tools and products* (→ **page 47**).

Table 6

Tightening torque values for cover bolts and attachment bolts

Housing Size	Cover bolts		Attachment bolts	
	Size	Tightening torque	Size	Tightening torque ¹⁾
–	–	Nm	–	Nm
FNL 505	M 5 × 16	6	M 10	50
FNL 506	M 5 × 16	6	M 10	50
FNL 507	M 5 × 16	6	M 12	80
FNL 508	M 5 × 16	6	M 12	80
FNL 509	M 6 × 20	10	M 12	80
FNL 510	M 6 × 20	10	M 12	80
FNL 511	M 6 × 20	10	M 12	80
FNL 512	M 6 × 20	10	M 12	80
FNL 513	M 6 × 20	10	M 12	80
FNL 515	M 8 × 25	24	M 16	200
FNL 516	M 8 × 25	24	M 16	200
FNL 517	M 8 × 25	24	M 16	200
FNL 518	M 8 × 25	24	M 16	200
FNL 520	M 10 × 30	47	M 20	385
FNL 522	M 10 × 30	47	M 20	385

¹⁾ Recommended by bolt manufacturers

Ordering information

FNL housings are supplied together with their standard seals. Each of the following items must be ordered separately:

- housing
- locating rings or spacing washer
- bearing
- adapter sleeve

Order example

Two FNL flanged housings are required for two 22212 EK spherical roller bearings on H 312 adapter sleeves. One housing will accommodate the non-locating bearing at the end of the shaft. The other housing will accommodate the locating bearing and a through shaft.

The following items should be ordered (in addition to the bearings and adapter sleeves):

- 1 housing FNL 512 A
- 1 housing FNL 512 B
- 1 spacing washer ZW 90x110

11.1 FNL flanged housings for bearings on adapter sleeves

d_a 20 – 40 mm

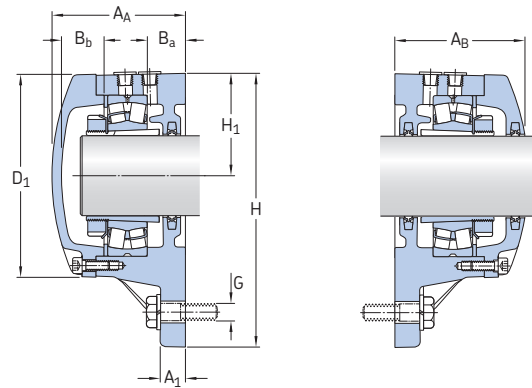

Shaft diameter d_a	Housing for shaft end	for through shaft	Appropriate parts			
			Bearing ¹⁾	Adapter sleeve ²⁾	Locating ring or spacing washer ³⁾	Contact seal
mm	-		-			
20	FNL 505 A	FNL 505 B	1205 EKTN9 2205 EKTN9 22205 EK C 2205 KTN9	H 205 H 305 H 305 H 305 E	1 FRB 5/52 1 ZW 42 × 52 1 ZW 42 × 52 1 ZW 42 × 52	TFL 505
25	FNL 506 A	FNL 506 B	1206 EKTN9 2206 EKTN9 22206 EK C 2206 KTN9	H 206 H 306 H 306 H 306 E	1 FRB 6/62 1 ZW 50 × 62 1 ZW 50 × 62 1 FRB 2/62	TFL 506
30	FNL 507 A	FNL 506 B	1207 EKTN9 2207 EKTN9 22207 EK C 2207 KTN9	H 207 H 307 H 307 H 307 E	1 FRB 8/72 1 ZW 65 × 72 1 ZW 65 × 72 1 ZW 65 × 72	TFL 507
35	FNL 508 A	FNL 508 B	1208 EKTN9 2208 EKTN9 22208 EK C 2208 KTN9	H 208 H 308 H 308 H 308 E	1 FRB 7/80 1 ZW 70 × 80 1 ZW 70 × 80 1 ZW 70 × 80	TFL 508
40	FNL 509 A	FNL 509 B	1209 EKTN9 2209 EKTN9 22209 EK C 2209 KTN9	H 209 H 309 H 309 H 309 E	1 FRB 6/85 1 ZW 75 × 85 1 ZW 75 × 85 1 ZW 75 × 85	TFL 509

¹⁾ Only the basic bearing designation is listed. Other bearing variants can also fit the housing.
12(00), 22(00) – self-aligning ball bearing, 222(00) – spherical roller bearing, C... – CARB toroidal roller bearing

²⁾ The adapter sleeve fits the bearing in the same row only.

³⁾ The locating ring or spacing washer fits the bearing in the same row only.

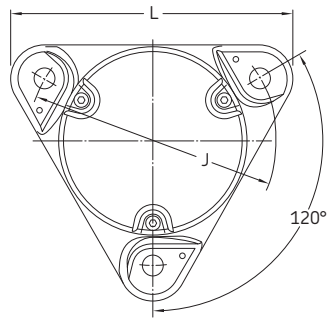

Shaft diameter	Dimensions Housing											Mass Housing
	d_a	A_A	A_B	A_1	B_a	B_b	D_1	H	H_1	J	L	
mm	mm											kg
20	57	56,5	10	15	15	74	100	38	96	110	10	1,10
25	60,5	60	12	16	15	86	117	44	116	130	10	1,60
30	64,5	64	12	16	17	95	130	48,5	130	145	12	2,00
35	67	66	12	17	18	105	143	54	140	160	12	2,40
40	72	70,5	12	19	19	113	160	60	160	179	12	3,20

11.1

11.1 FNL flanged housings for bearings on adapter sleeves

d_a 45 – 60 mm

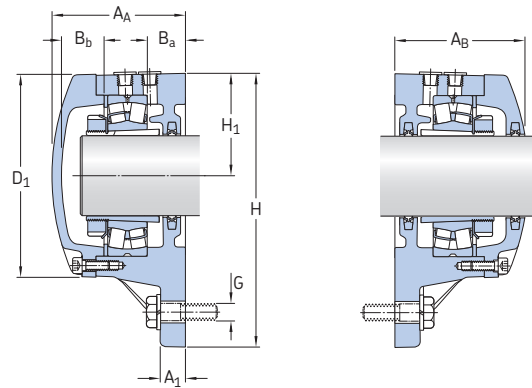

Shaft diameter d_a	Housing for shaft end	for through shaft	Appropriate parts			
			Bearing ¹⁾	Adapter sleeve ²⁾	Locating ring or spacing washer ³⁾	Contact seal
mm	-	-	-	-	-	-
45	FNL 510 A	FNL 510 B	1210 EKTN9 2210 EKTN9 22210 EK C 2210 KTN9	H 210 H 310 H 310 H 310 E	1 FRB 5/90 1 ZW 80 x 90 1 ZW 80 x 90 1 ZW 80 x 90	TFL 510
50	FNL 511 A	FNL 511 B	1211 EKTN9 2211 EKTN9 22211 EK C 2211 KTN9	H 211 H 311 H 311 H 311 E	1 FRB 6/100 1 ZW 85 x 100 1 ZW 85 x 100 1 ZW 85 x 100	TFL 511
55	FNL 512 A	FNL 512 B	1212 EKTN9 2212 EKTN9 22212 EK C 2212 KTN9	H 212 H 312 H 312 H 312 E	1 FRB 8/110 1 ZW 90 x 110 1 ZW 90 x 110 1 FRB 2/110	TFL 512
60	FNL 513 A	FNL 513 B	1213 EKTN9 2213 EKTN9 22213 EK C 2213 KTN9	H 213 H 313 H 313 H 313 E	1 FRB 10/120 1 FRB 2/120 1 FRB 2/120 1 FRB 2/120	TFL 513

¹⁾ Only the basic bearing designation is listed. Other bearing variants can also fit the housing.
12(00), 22(00) – self-aligning ball bearing, 222(00) – spherical roller bearing, C... – CARB toroidal roller bearing

²⁾ The adapter sleeve fits the bearing in the same row only.

³⁾ The locating ring or spacing washer fits the bearing in the same row only.

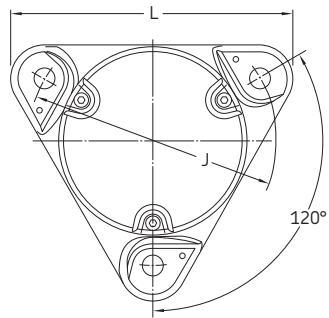

Shaft diameter	Dimensions Housing											Mass Housing
	d_a	A_A	A_B	A_1	B_a	B_b	D_1	H	H_1	J	L	
mm	mm											kg
45	77	75	15	22	21	118	160	60	160	179	12	3,50
50	84	82	15	24	23	127	172,5	65	170	192	12	4,30
55	85	83	15	23	22	142	189	72	180	210	12	5,20
60	88	86	15	22	24	152	203	78	190	225	12	6,30

11.1

11.1 FNL flanged housings for bearings on adapter sleeves

d_a 65 – 100 mm

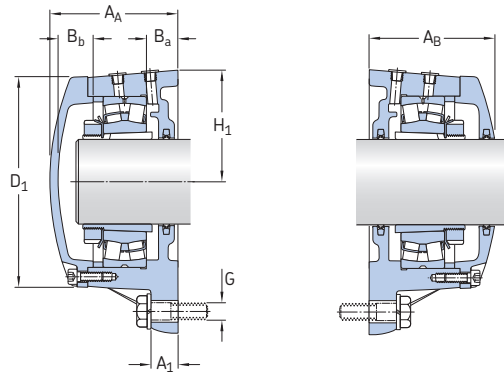

Shaft diameter d_a	Housing for shaft end	for through shaft	Appropriate parts			Contact seal
			Bearing ¹⁾	Adapter sleeve ²⁾	Locating ring or spacing washer ³⁾	
mm	-		-			
65	FNL 515 A	FNL 515 B	1215 K 2215 EKTN9 22215 EK C 2215 K	H 215 H 315 H 315 H 315 E	2 FRB 8/130 1 FRB 10/130 1 FRB 10/130 1 FRB 10/130	TFL 515
70	FNL 516 A	FNL 516 B	1216 K 2216 EKTN9 22216 EK C 2216 K	H 216 H 316 H 316 H 316 E	2 FRB 8,5/140 1 FRB 10/140 1 FRB 10/140 1 FRB 10/140	TFL 516
75	FNL 517 A	FNL 517 B	1217 K 2217 K 22217 EK C 2217 K	H 217 H 317 H 317 H 317 E	2 FRB 9/150 1 FRB 10/150 1 FRB 10/150 1 FRB 10/150	TFL 517
80	FNL 518 A	FNL 518 B	1218 K 2218 K 22218 EK C 2218 K	H 218 H 318 H 318 H 318 E	2 FRB 10/160 1 FRB 10/160 1 FRB 10/160 1 FRB 10/160	TFL 518
90	FNL 520 A	FNL 520 B	1220 K 2220 KM 22220 EK C 2220 K	H 220 H 320 H 320 H 320 E	1 FRB 10/180 ⁴⁾ 1 FRB 12/180 ⁴⁾ 1 FRB 10/180 1 FRB 10/180 1 FRB 10/180	TFL 520
100	FNL 522 A	FNL 522 B	1222 K 2222 KM 22222 EK C 2222 K	H 222 H 322 H 322 H 322 E	2 FRB 12,5/200 1 FRB 10/200 1 FRB 10/200 1 FRB 10/200	TFL 522

¹⁾ Only the basic bearing designation is listed. Other bearing variants can also fit the housing.
12(00), 22(00) – self-aligning ball bearing, 222(00) – spherical roller bearing, C... – CARB toroidal roller bearing

²⁾ The adapter sleeve fits the bearing in the same row only.

³⁾ The locating ring or spacing washer fits the bearing in the same row only.

⁴⁾ One FRB 10/180 and one FRB 12/180 at each side of the bearing.

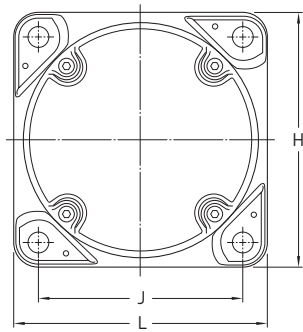

Shaft diameter	Dimensions Housing											Mass Housing
	d_a	A_A	A_B	A_1	B_a	B_b	D_1	H	H_1	J	L	
mm	mm											kg
65	106	104	25	30	24	168	190	95	152	190	16	10,0
70	113	110	25	31	27	175	196	98	152	196	16	10,5
75	117,5	115	25	31	27	188	210	105	170	210	16	12,5
80	121	118	25	30	28	196	210	105	170	210	16	12,0
90	130	127	30	30	31	224	250	125	198	250	20	19,0
100	140	137	30	30	33	244	270	135	219	270	20	23,5

11.1